

HBLA UFO SERIES LED HIGH BAY LIGHT

Power:240W



Feature

- Radiator surface spray processing anticorrosion performance, cooling effect is more, an organic whole die-casting lamp, fastening structure.
- Imported Original Philips LEDs, with higher lumen efficacy, energy saving and better illumination effect.
- Meanwell driver, full voltage, can be applied in various environments.
- Beam angle: 60°, 90°, 120°.
- 5 years warranty, life-time maintenance at cost price.
- Protection Grade: IP65 waterproof.



Product details

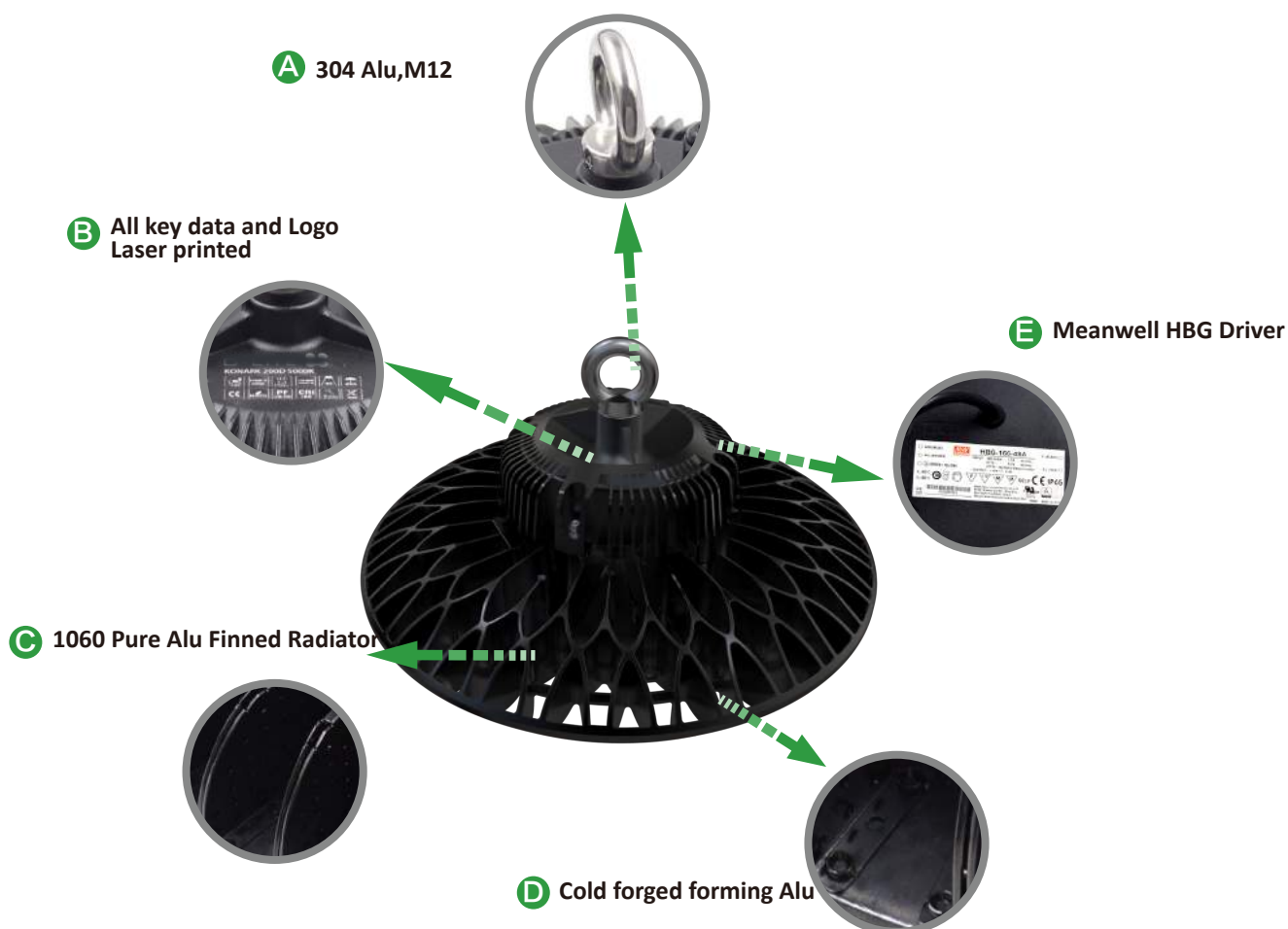

Explosive view

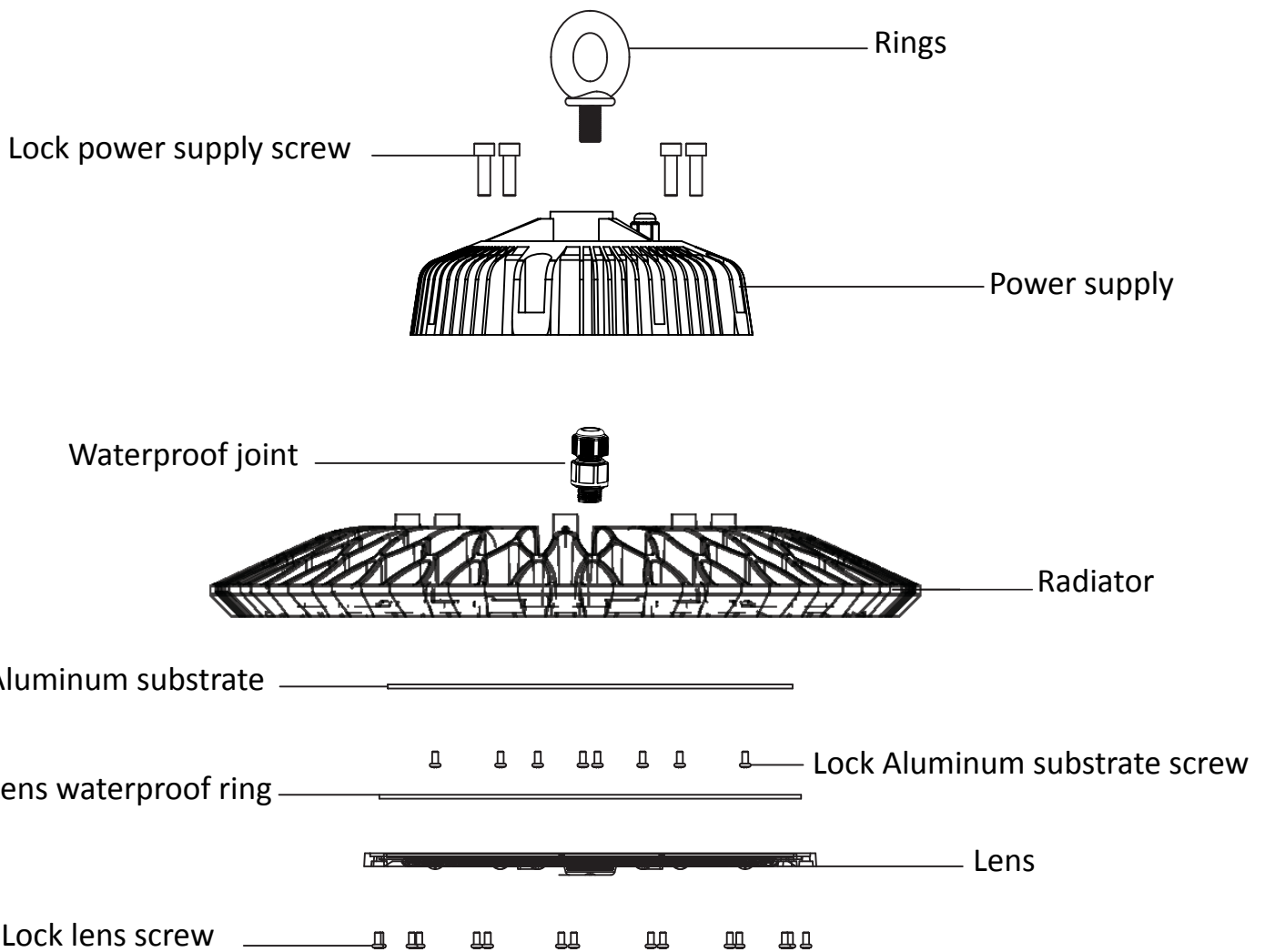

Scene display

Applied to indoor high industrial factory building, gymnasium, workshop, equipment manufacturing factory,warehouse, workshop, ceiling lighting, etc., etc.



The workshop



The high building

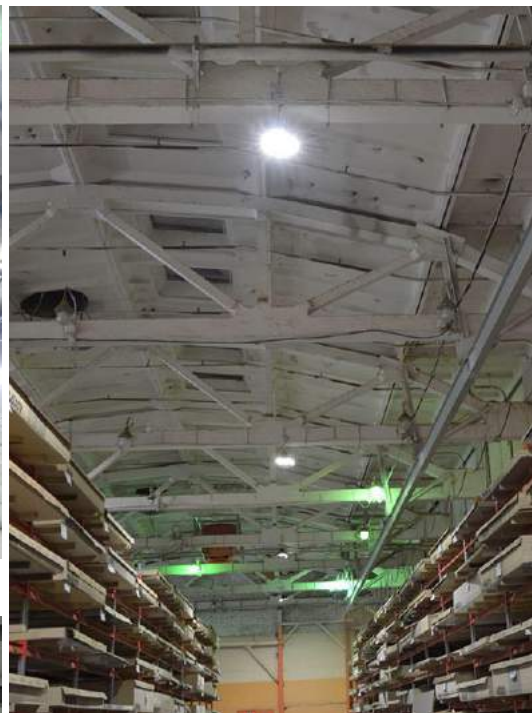

Warehouse



The stadium

GH-HBLA-240W



Specifications

Model	GH-HBLA-240W		
Input watt	240W		
Luminous Efficacy	> 140LM/W		
Input voltage	AC85-265V		
Frequency (Hz)	50-60HZ		
Power factor	>0.98		
CCT	3000K±200K	4000K±200K	6500K±200K
LED chip&Qty	SMD3030 (315PCS)		
Driver	Meanwell Driver		
CRI	>80		
Product size	Ø400*180mm		
N.W.	6.0kg		
Environment temperature	-20°C-+45°C		
Certificates	CE、ROHS		
Lifespan	50000H		
Warranty	5 years		

Product size

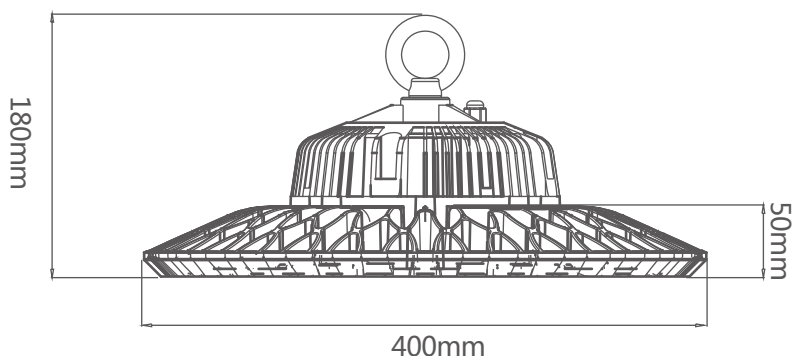

Package size

Product model	Power	Size	Net Weight	Carton size	Quantity
GH-HBLA-240W	240W	∅400*180mm	6.0kg	475*470*195mm	1pcs

The following is a neutral cowhide carton packing, such as the need to print LOGO, can be customized.

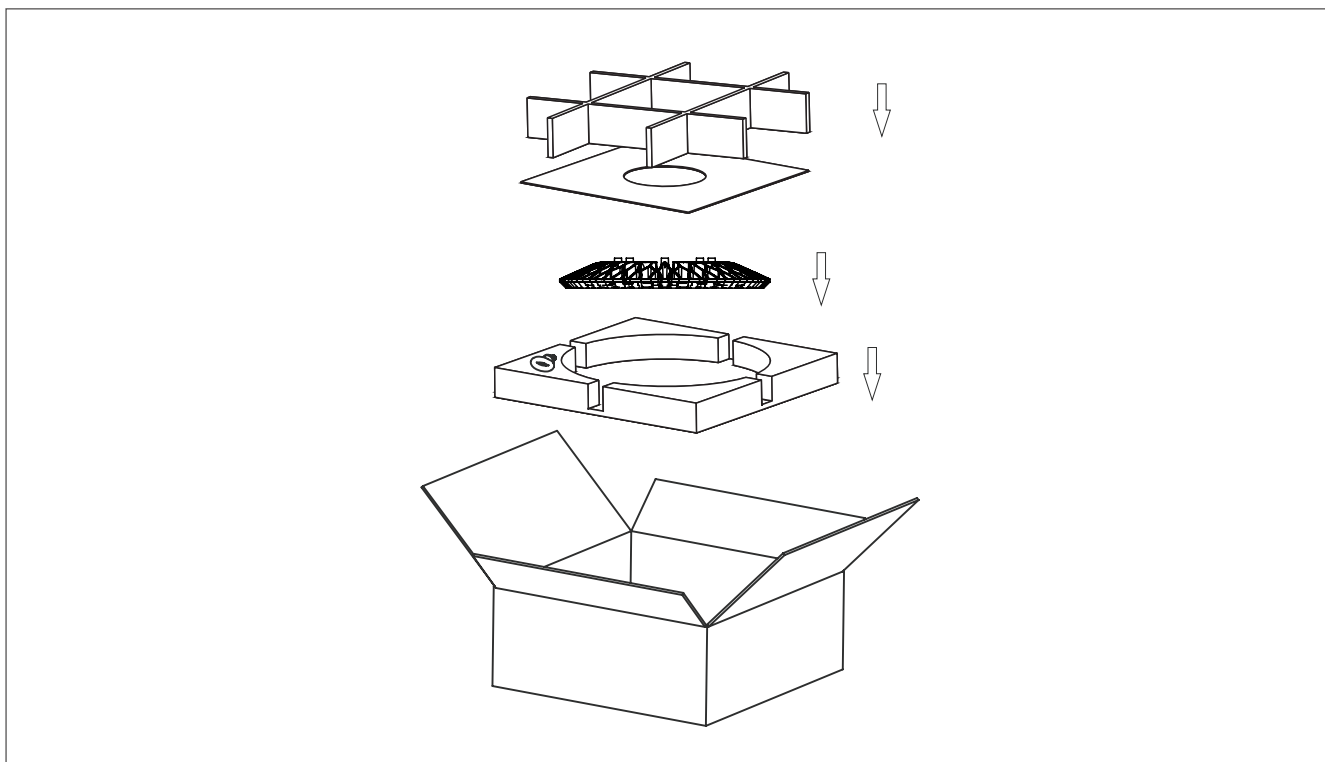

Installation

1. Safety is first.
2. This series of industrial and mining lamp light lifting, hook type two kinds of installation, wider application range.
3. The installation shall be completed by experienced electrician.
4. Any further questions, feel free to get us for more solutions.

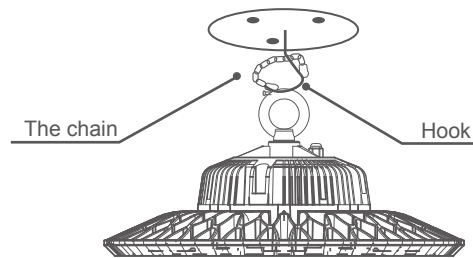

Cautions

- Lightning Protection: Meanwell driver can resist 4KV surge, if the using environment out of this range, please add higher grade surge terminal.
- Degree of Protection: IP65, can be applied outdoor, but immersed in water. The tempered glass shall not be knocked by any pointed thing.
- Don't install or use it in a humid environment or place which has water drops.
- Don't take apart the product or replace mechanical and electronic components.
- Don't stare at the strong light for a long time as it may cause injury to eyes.
- No specific requirements, the wires shall be 3*0.75 without plug, if yes, keep it informed by the sales.
- This series of lights are not compatible with ballast, when replacing the traditional lamps, please remove the ballast or contact us for more solutions.

Aging test



Test report

IES test

